

# FORGED EYE BOLT WARNINGS AND APPLICATION INSTRUCTIONS

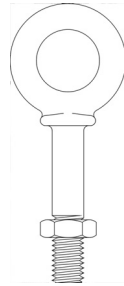

Regular Nut Eye Bolt  
G-291



Shoulder Nut Eye Bolt  
G-277



Machinery Eye Bolt  
S-279 / M-279

## Important Safety Information - Read & Follow

### Inspection/Maintenance Safety:

- Always inspect eye bolt before use.
- Never use eye bolt that shows signs of wear or damage.
- Never use eye bolt if eye or shank is bent or elongated.
- Always be sure threads on shank and receiving holes are clean.
- Never machine, grind, or cut eye bolt.

### Assembly Safety:

- Never exceed load limits specified in Table I & Table 2.
- Never use regular nut eye bolts for angular lifts.
- Always use shoulder nut eye bolts (or machinery eye bolts) for angular lifts.
- For angular lifts, adjust working load as follows:

Direction of Pull (in-line)	Adjusted Working Load
45 degrees	30% of rated working load
90 degrees	25% of rated working load

- Never undercut eye bolt to seat shoulder against the load.
- Always countersink receiving hole or use washer with sufficient I.D. to seat shoulder.
- Always screw eye bolt down completely for proper seating.
- Always tighten nuts securely against the load.

Size (in.)	Working Load Limit (lbs.)
1/4	650
5/16	1,200
3/8	1,550
1/2	2,600
5/8	5,200
3/4	7,200
7/8	10,600
1	13,300
1-1/8	15,000
1-1/4	21,000
1-1/2	24,000
1-3/4	34,000
2	42,000
2-1/2	65,000

## WARNING

- Loads may slip or fall if proper eye bolt assembly and lifting procedures are not used.
- A falling load can seriously injure or kill.
- Read and understand both sides of these instructions, and follow all eye bolt safety information presented here.
- Read, understand, and follow information in diagrams and charts below before using eye bolt assemblies.

## Shoulder Nut Eye Bolt — Installation for Angular Loading

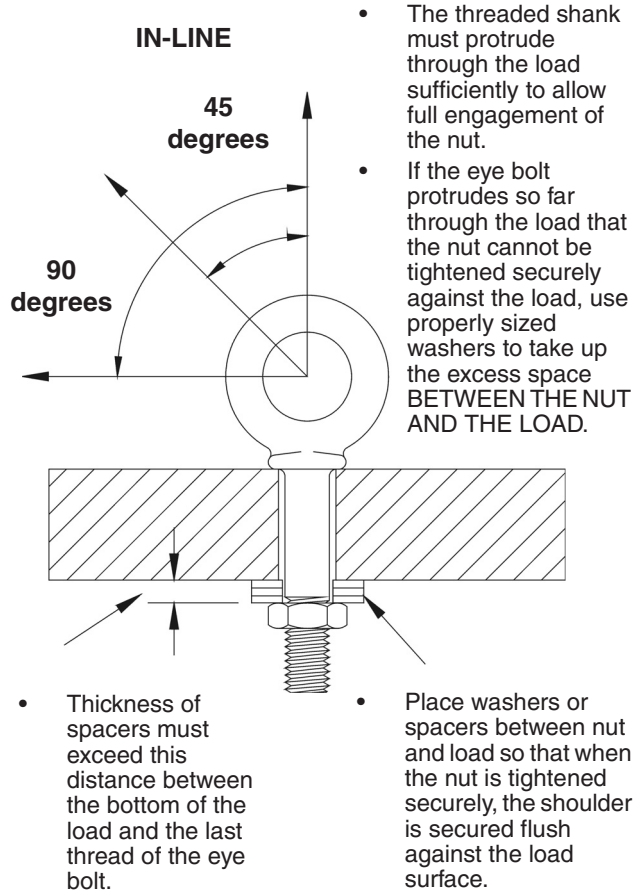

Metric Size	Working Load Limit - kg
m6	200
m8	400
m10	640
m12	1000
m16	1800
m20	2500
m24	4000
m27	5000
m30	6000
m36	8500
m42	14000
m48	17300
m64	29500